

BENTEK SYSTEMS LTD

SCADA and Telemetry Solutions

**SCADALink Sensor Radio
SR-900T / SR900R**



Wireless Simplex I/O Controller

User Manual

Version V1.05 for SCADALink SR-900T / SR-900R

(Last revised Mar 14, 2007)

BENTEK SYSTEMS LTD

504 - 42 Ave S.E. Calgary, Alberta, Canada T2G 1Y6 Ph: (403) 243-5135 Fax: (403) 243-5165
email: support@scadalink.com web: www.scadalink.com



Applications with Multiple Receiver Sites:

Sensor Radios can also be used in systems with a single Transmitter transmitting to multiple Receivers keyed to the same Transmitter. This allows the inputs at the Transmitter to be replicated at all the Receivers. Typical applications are in Pump Control and Shutdown Systems.

Pump On/Off Control:

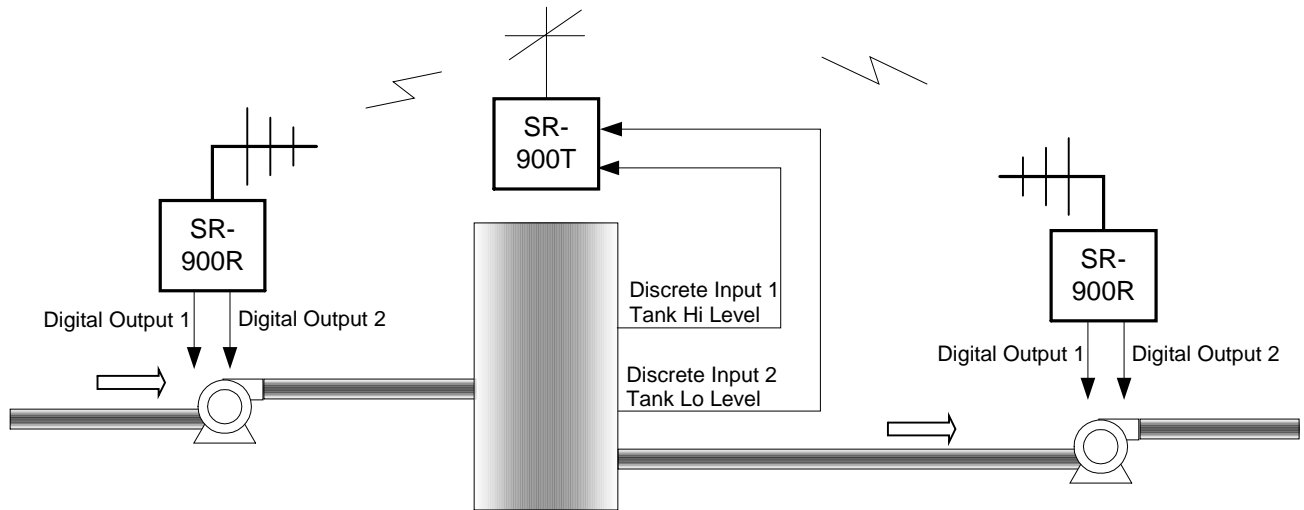

Shutdown System:

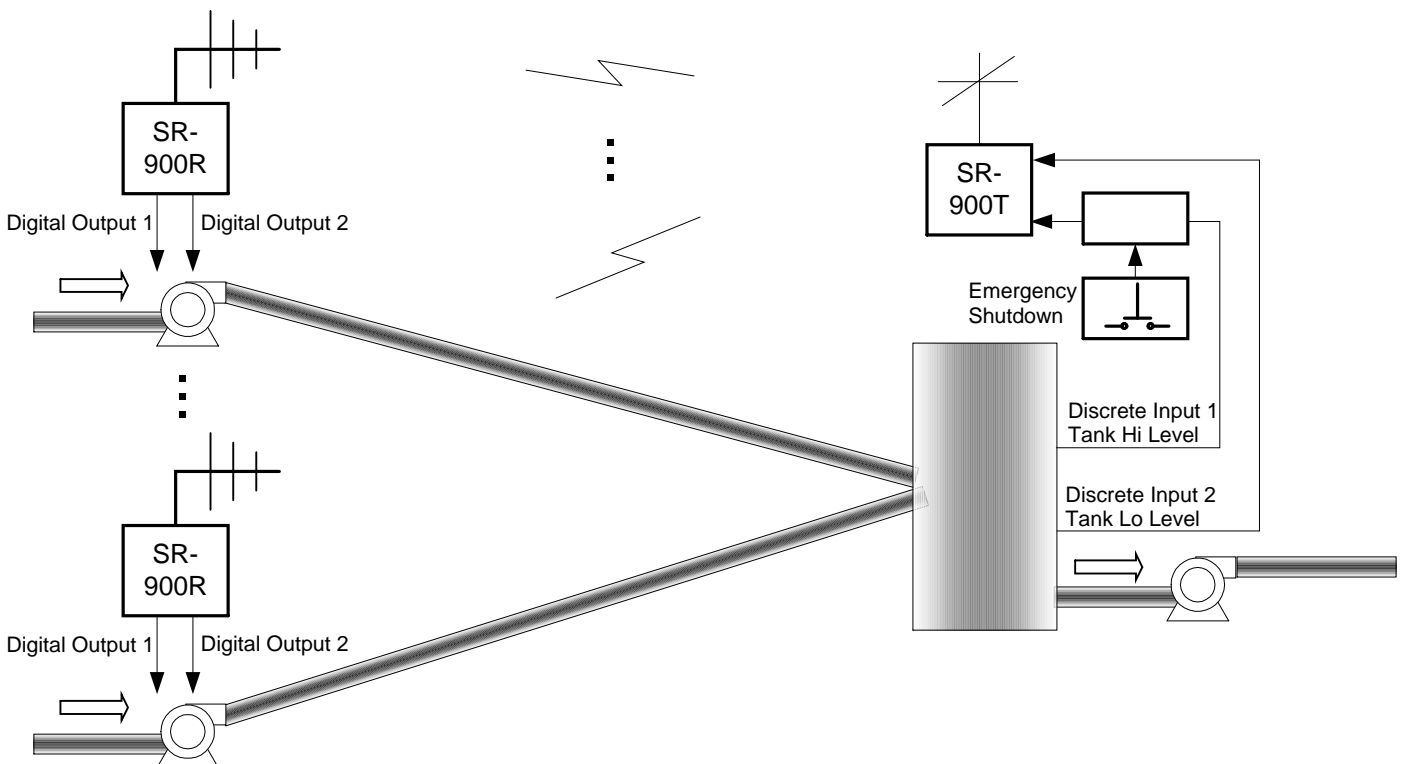



SR-900T Radio Transmitter Wiring Diagrams

Two Wire Loop Powered Transmitter

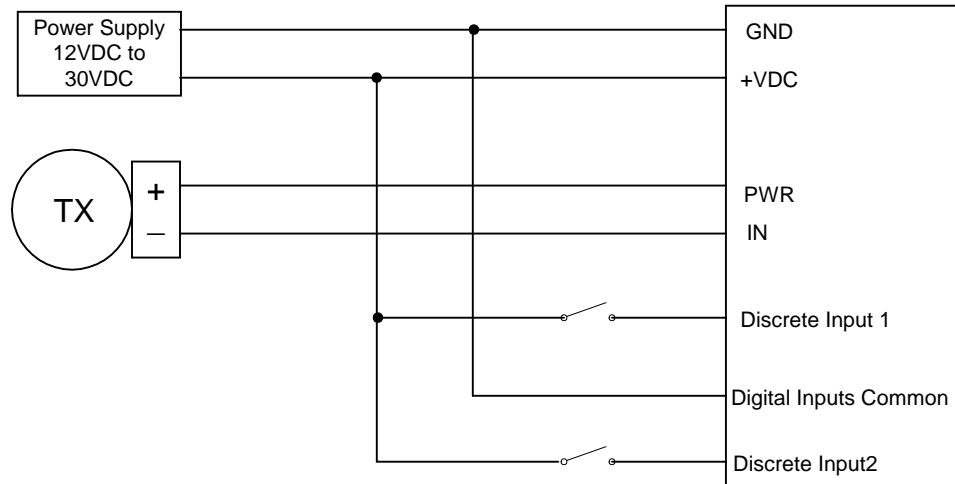

SR-900T Transmitter

Three Wire Transmitter

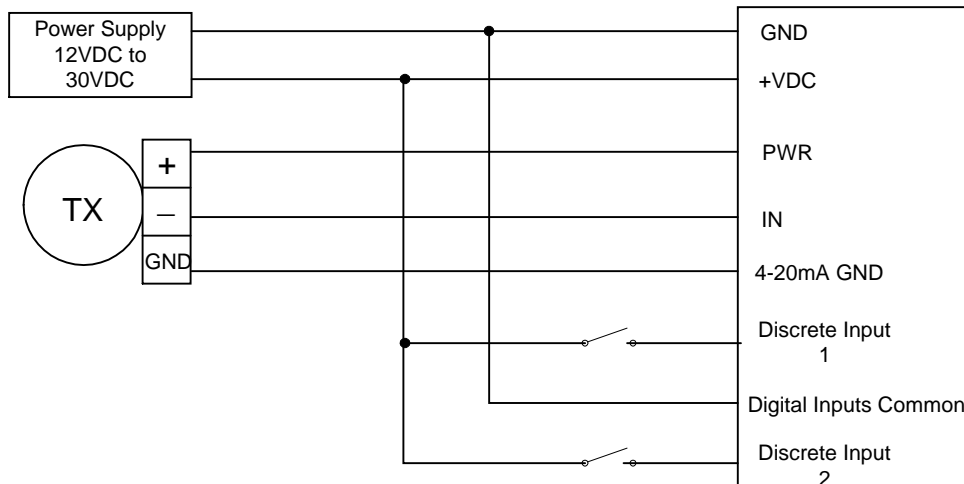

SR-900T Transmitter

Externally Powered 4 Wire Transmitter

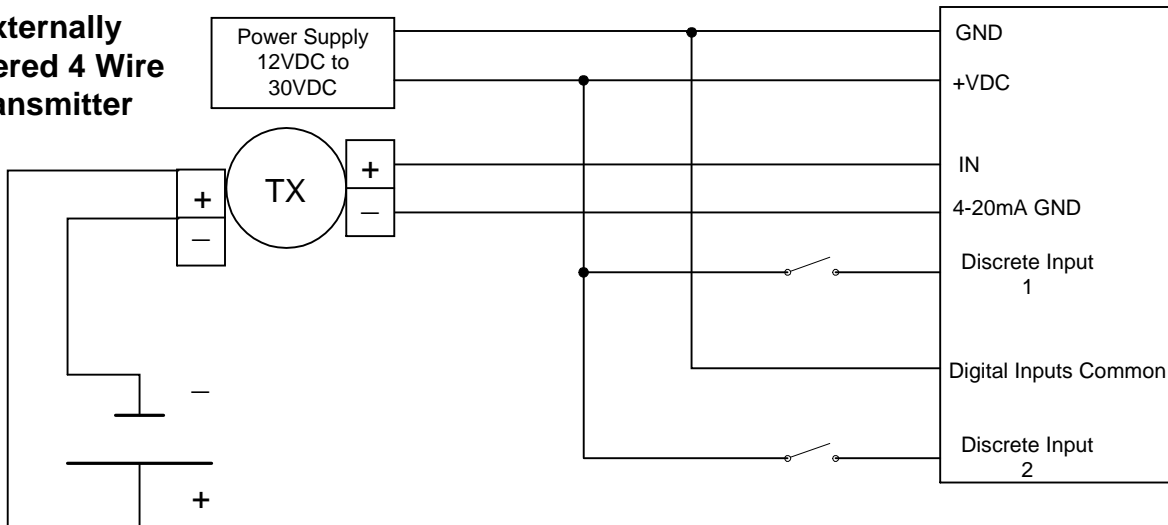

SR-900T Transmitter



SR-900T Radio Transmitter Wiring Diagram

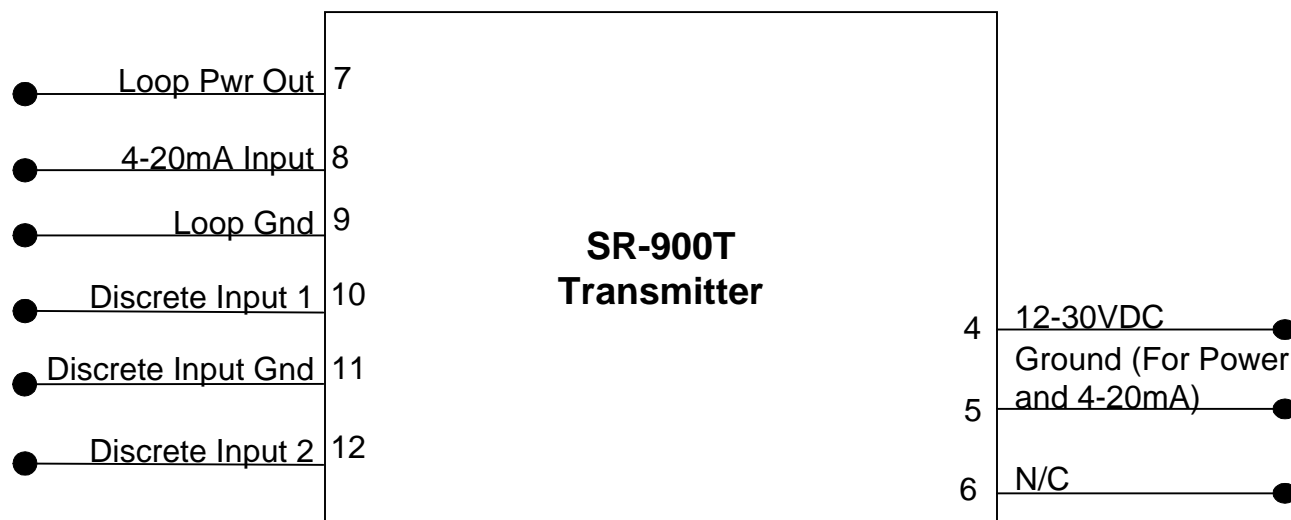

SR-900T Transmitter LED's

RF LED: Solid Green when functioning normally.

LED's 1 and 2 show status of digital inputs 1 & 2. Solid Green = ON.

N/C: No Connection

WARNING: EXPLOSION HAZARD

Do not disconnect equipment unless power has been switched off or the area is known to be non-hazardous.



SR-900R Radio Receiver Wiring Diagram

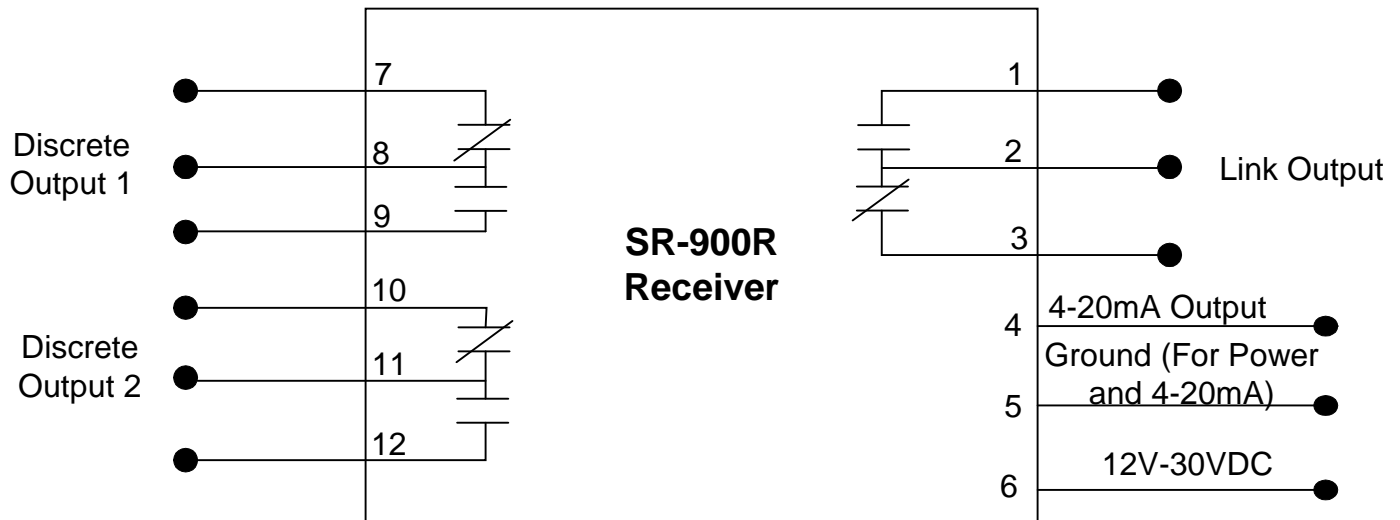

SR-900R Receiver LED's

RF LED Blinks once every 2 seconds when transmitter is OFF or out of range.

RF LED Blinks rapidly when marginal signal is being received.

RF LED is solid when a secure link is established.

LED's 1 & 2 show status of digital inputs 1 & 2. Solid Green = ON.

FCC: This device complies with Part 15 of the FCC rules. Operation is subject to the following 2 conditions:

1. This device may not cause harmful interference.
2. This device must accept interference received, including interference that may cause undesired operation.

Changes or modifications not expressly authorized by Bentek Systems Ltd. could void the user's authority to use the equipment. The system integrator may only use antennas that have been tested and approved with this radio to maintain the FCC approval. If a system integrator uses non-approved antenna they are responsible for obtaining their own FCC certification.

WARNING: EXPLOSION HAZARD

Do not disconnect equipment unless power has been switched off or the area is known to be non-hazardous.



RSSI Chart vs. Voltage

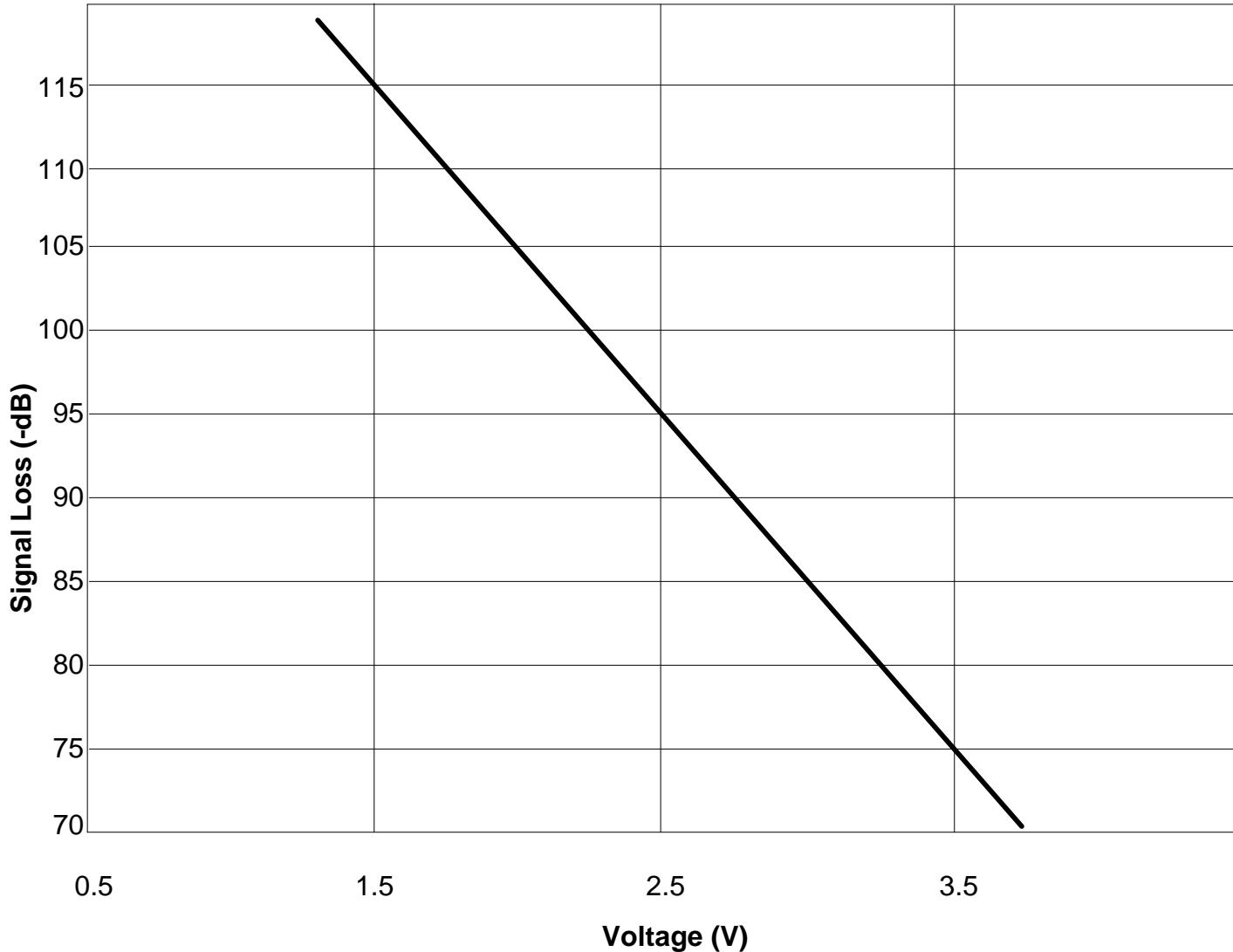

RSSI is a Receiver pin that indicates the Receiver's received signal strength. It is measured by placing the probes of a voltmeter (on a DC Voltage setting) between the RSSI pin and GND. A value of 2.5V or greater is required for proper Receiver operation while a value less than 2.5V will result in potentially unreliable radio operation. If RSSI is below 2.5V, Signal strength at the Receiver can be increased by:

1. using a higher gain antenna
2. better antenna orientation to Transmitter (if Receiver antenna is a directional antenna)
3. moving antenna to a higher elavation (or increasing height of antenna tower)
4. moving antenna to a location where there are fewer obstructions.