

**IP100 used for RS232 Switching for SCADA Communications
to Redundant AB ControlLogix PLC System**

The IP100 has been augmented with the DI controlled select mode for use with RS232 Switching of Modem Connection to Redundant AB ControlLogix System. Figure 1 below shows the operation.

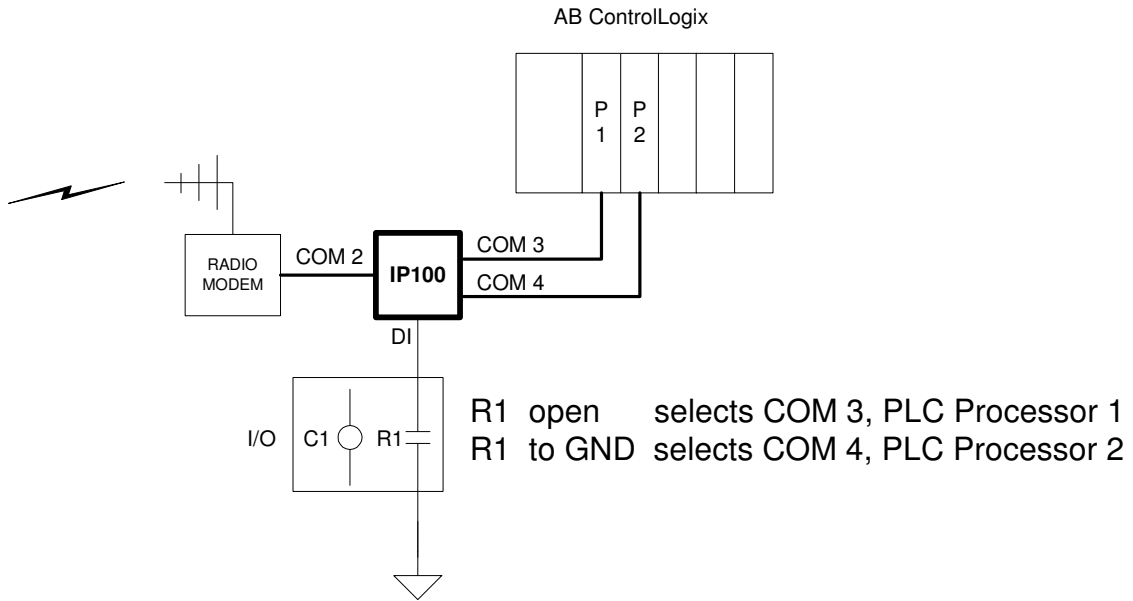

Figure 1: RS-232 Switching between redundant PLC Processors